



Cuivre River Electric Cooperative

A Touchstone Energy[®] Cooperative 

For more information contact: Engineering Department (636) 695-4904

RURAL RESIDENTIAL SERVICE INSTALLATION GUIDE Form # UG40

Cuivre River Electric Cooperative can provide many options for receiving electric service at your rural home or building. A rural service is defined by the Cooperative to be any service outside of a platted development or a service within a development with a lot size equal to or greater than 3 acres. For un-platted properties, there are several options for making electric service available to a location depending on the nature of the property and the needs of the Member. These options are described below. If your home or building is remote to an electric line, please see **Section VI. Other Service-Related Items**. For most new Members, the immediate concerns are with sizing the service and having the service installed. These concerns can be discussed with our Service Planning Technician during your appointment or by contacting them by phone or email. The following is a brief overview of the topics that may be involved with establishing your new electric service. The topics begin with the installation of the service and related conduit to the home or building. These sections are critical for you to obtain your service in a timely fashion and without incurring additional cost. The sections that follow will provide you with further information and support for your discussions with our Service Planning Technician.

I. Service Installation- Rural Services and Lot Size \geq 3 Acre

The Member is responsible for establishing a continuous conduit from the transformer to the home or building. It is normally cost-efficient for the Member, or an entity contracted by the Member, to dig this trench and install the conduit—especially if you are also installing water lines. You can request the Cooperative to fully install your service. It will be installed when your meter base and main panel have been installed, wired, and inspected and you are ready to receive electric service. The cost for this option should be discussed with the Service Planning Technician.

The trench must be deep enough to allow 36" of cover over the conduit along the entire length. If solid rock is encountered, **it will need to be removed** to install the conduit at the prescribed depth. With rock, bedding with screenings may be required to protect the conduit.

If the service is from an overhead line (a pole), the conduit will need to be extended to the base of the pole, terminating with a 36" radius conduit elbow and a short section of conduit placed, but not glued, in the elbow to extend the conduit above grade. This section of conduit should not be glued as it will be replaced by the Cooperative's wire installation crew. If the service is from new underground facilities, the Cooperative will have a conduit stub out from the base of the transformer. The Member will connect their conduit to this stub and extend the continuous conduit to the meter base on the home or building. See the details in the Conduit Installation section. If the service is from existing underground facilities, the Member should contact the Cooperative and make arrangements to connect their conduit to the existing facilities. If in any doubt, Members should contact the Cooperative to make arrangements. When planning the route for the underground service, it is advantageous to think about the future. Relatively inexpensive options incorporated now can save hundreds of dollars in the future. If there is any possibility that a deck, swimming pool, retaining wall, or outbuilding will be installed at some point in the future, the Member should be mindful to route their service around these things. If that is not practical, the Member should install the service wire conduit at a depth that will avoid interference with future construction. Members should also consider the locations of trees on the property to minimize harm to the root system or damage to the conduit from the root system. Stay at least ten feet away from any large type of tree species to avoid the roots entangling the conduit system and damaging the conduit in the event of the tree toppling. The next thing to consider is the final grade of the yard. The Member must make sure the conduit is buried deep enough so that a depth of 36 inches of soil is maintained on top of the conduit when final grading is completed. The electric service and related conduit system may be installed with a water line, Member wire, or other utilities. If you use the trench for these other purposes, you will need to open the trench with a backhoe having at least an 18-inch wide bucket. Other facilities must have one foot of horizontal separation from the electric line; electric on one side of the trench, all other on the other side.

II. Conduit Installation

Conduit is always required on secondary services in to protect the wire, aid in service wire installation, and aid potential future replacement. The Member is required to supply the conduit. It is strongly recommended for the Member to install the conduit at the time the trench is opened. This negates the risk of the trench caving in before the conduit is installed, thus causing the expense of re-trenching.

Any additional material needed by the Cooperative to remedy issues with the Member's installation will be billed at the Cooperative's cost-plus tax and a handling charge.

The required conduit size is 2 ½ inch, Schedule 40, gray electrical grade for 4/0 and 350 MCM service wires. 3-inch, Schedule 40 conduit is required for 500 MCM service wires.

The conduit will lie at the bottom of a trench with a minimum cover of 36 inches from the top of the conduit to finished grade. Conduit lengths must be coupled together utilizing PVC cement.

A conduit run can have no more than 360 degrees of bends or turns. This is a physical limitation on the ability to pull wire through the conduit. A straight run of conduit will start with 180 degrees of bends which includes the 90-degree elbow at the transformer and another at the meter base. The Member is therefore limited to two additional 90 degree turns or a summation of lesser turns equaling 180 degrees. This summation may be achieved by utilizing elbows or long sweeping turns, bending the conduit in an arcing trench. All elbows installed in the conduit run must have no **less than a 36-inch radius**. The use of the small 12-inch elbows that are more readily available will cause the Member's conduit installation to be rejected as our crews may be unable to push the stiff secondary wire through the tight elbow.

A pull line is required to be installed in the conduit run for all installations. The pull line must have a tensile strength greater than 200 pounds and be capable of pulling in a heavier pull rope or steel cable; this may be required to install the service wires depending on the length and number of degrees of turns.

The pull line can typically be easily installed after the conduit system is laid by utilizing a plastic grocery bag and a leaf blower or the blower side of a shop vacuum. If the Member is not able to install a pull line in the conduit, it is highly likely that the line crew will not be able to install the wire in the conduit.

The Cooperative will assess the depth of the conduit when they arrive to install the service wires. If the depth is not adequate or the crew is unable to install the service wires because the conduit was not installed correctly, the **Member will be billed a service charge of \$500.00** and shall be required to correct the deficiency before the service installation is rescheduled.

III. Temporary Construction Service

Temporary metered service can be supplied by the Cooperative if requested. Temporary services can be set up to supply construction power from either overhead or underground power lines. The service point for overhead facilities will

be within 20 feet of the pole and for underground, within five feet of the right side of the pad mounted transformer or secondary pedestal. The service must be safely designed, meeting all required codes. All circuits must be protected with Ground fault Interrupter receptacles or circuit breakers (GFI's). A diagram for an overhead temporary service is included with this guide.

Temporary service may be established at the permanent meter base location if ground conditions and building construction will allow the installation of the permanent meter base and service wires.

Some communities require inspections for temporary services. Please check with your local planning and zoning officials or our engineering department.

IV. Service Size

The Member should consult with an electrician or review the National Electrical Code to determine the appropriately sized service for their needs. The typical service sizes for a home or outbuilding are: 100, 200, or 320 Amp. The minimum sized meter base approved by the Cooperative is 200 Amp. The Member is responsible for purchasing and installing a meter base approved by the Cooperative. The Cooperative's design practice requires secondary wire length and/or size be selected such that the full rated service of the meter base is available (a 200A meter base must be able to be supplied 200A with acceptable voltage drop, service length and necessary capacity will dictate the wire size required to provide this). **Only meter bases approved by the Cooperative may be used by the Member.**

V. Metering

Meter Bases

The size and type of meter base required is determined by the main panel(s) size or service size. For a basic service for a home or building, a 200-amp meter base will be adequate for a service rated 200 amps or lower. If more circuits are required, a 320-amp base will allow for (2) 200-amp panels. If an outbuilding or a detached garage service is anticipated, a 200- or 320-amp base with a breaker panel may be applicable. A catalog of approved Milbank meter bases is available upon request.

The following is condensed listing of meter base types:

- 200 Amp Basic (overhead or underground service)
- 200 Amp w/main & 8 position breaker panel (well, outbuilding...)
- 200 Amp meter pedestal w/ main & 4 position breaker panel (A/C, yard light...)
- 320 Amp

- 320 Amp w/ (2) 200 Amp mains
- 320 Amp w/ (2) 200 Amp mains & 12 position breaker panel
- 20 Amp meter base for CT metering (600-amp service)

Residential services 600 Amps and greater will require current metering transformers (CT's). These CT's and their bases are supplied by the Cooperative and can be placed in an outdoor rated metering cabinet (24" x 24" x 10" minimum size). This metering cabinet will be supplied and mounted by the Member on the outside wall of the building (see metering catalog for specific size and type). The 20-amp meter base must be mounted by the Member adjacent to the metering cabinet. The Cooperative will make service available at an approved secondary pedestal or pull box located within 10 feet of the transformer. The Member will be responsible for supplying and installing the pedestal, trench, conduit, and conductors from the pedestal to the CT cabinet at the structure. The Cooperative will provide all metering wiring and connections.

If the transformer is dedicated to the service, the metering CT(s) may be installed in the secondary bay of the transformer. A metering assembly must then be installed adjacent to the transformer. The Service planning Technician will provide you with more detailed instruction for this type of installation.

Meter Base on a Building

Meter bases mounted on a building must be securely attached to stringers between structural elements or firmly attached to structural walls such as concrete or block. Meter bases must be attached with screws, nailing is not acceptable. Anchoring to siding or wall boards is also not acceptable. Weak attachments will create problems in the future when the base pulls away from the building. Meter bases will be inspected and given a pull test by the serviceman before meters will be set.

The soil below the trench at the meter base location must be thoroughly compacted or jetted with water prior to cable installation. This will prevent the conduit from settling which will cause damage to the meter base. **The Member will be responsible for obtaining an electrician to reattach any meter base to the home and for any damages that occur to the meter base because of cable or conduit settling.** A fully collapsed slip joint section of conduit with 18-24 inches of travel must be installed for all meter bases attached to a building. It is further recommended to install a heavy grade conduit hanger below the slip joint which is firmly attached to the building foundation.

Meter bases attached to a home or building must be located **within 10 feet of the corner of the structure nearest to the transformer supplying service.** If the nearest point is a garage or other area in which you do not want to install the main

panel, a service disconnect at the meter base may be required to extend the entrance wire to the main panel. The National Electric Code requires over-current protection and a service disconnecting means on the outside of the building or inside the building at the nearest point of entrance of the service conductors. Alternative meter base locations may be allowed with the approval of the Cuivre River Electric Service Planning Technician if an attached garage is the part of the building which is nearest to the transformer. There will be no allowance for wrapping the meter base location around the corner of a building. The meter base must be along one of the two walls closest to the transformer.

The maximum height for the meter base on a structure is 6 feet at the top of the meter base and the minimum is 2.5 feet from finished grade to the bottom of the base. The knockout located on the left side of the bottom of the meter base is reserved for use by the Cooperative for the service wire that will extend from the transformer. The Member wires going into the house or structure from the meter base are to be terminated on the bottom lugs of the meter base (See Drawing B). After the meter base has been inspected, if required by the city or county, Cuivre River Electric will terminate its wire on the top lugs of the meter base and set the meter.

Cuivre River will have a ground rod installed at the transformer location to ground CREC equipment. The Member is required to provide and install a ground rod, a minimum of 5/8" x 8' copper clad, at the location where the service enters the home or building. The rod must be driven to below grade level and be connected with an approved clamp utilizing not less than a #6 AWG Solid copper wire.

The Member is responsible for supplying and installing the meter base and all electric facilities beyond that point. This includes installing and wiring the main distribution panel and the service entrance wire (SE) from the bottom lugs of the meter base to the main lugs of the distribution panel.

Note: You will need to contact the following Planning and Zoning Commissions or the appropriate municipality to have your meter base inspected. They will place a sticker (members may be required to retrieve the sticker from the appropriate entity themselves-always check) on your meter base when it passes inspection.

Any meter base failing to meet these requirements will not be energized by the Cooperative until such measures are taken by the Member to remedy the deficiency to satisfy these requirements.

<i>St. Charles Planning & Zoning</i>	<i>636-949-7345</i>	<i>St. Charles City</i>	<i>636-949-3222</i>
<i>Warren Co. Planning & Zoning</i>	<i>636-456-3044</i>	<i>St. Peters</i>	<i>636-477-6600</i>
<i>Lincoln County</i>	<i>Not required</i>	<i>O'Fallon</i>	<i>636-240-2000</i>
<i>Warrenton</i>	<i>636-456-3535</i>	<i>Wentzville</i>	<i>636-327-5101</i>
<i>Troy</i>	<i>636-528-4712</i>	<i>Lake Saint Louis</i>	<i>636-625-1200</i>
		<i>Flint Hill</i>	<i>636-561-3737</i>

Meter Pedestals

A meter pedestal can be a manufactured meter base and pedestal assembly or a field assembled meter base and service disconnect that is attached to embedded posts. Mounting posts must be new, treated 6 x 6 lumber or slotted metal channel (Uni-Strut) embedded in concrete. These can be utilized when the Cooperative's main service is overhead or underground. It can be used as an alternative to a meter pole, or when it is not possible or convenient to attach the meter base to a structure such as is the case with a mobile home. The pedestal will include a service disconnecting main circuit breaker and may include provisions to add additional circuit breakers for providing service to an outbuilding or a yard light. A diagram of a field assembled meter pedestal can be found in the back of this guide. The Cooperative will maintain the metering section of the meter pedestal. All other components will be maintained by the Member, including the main and secondary breakers and the replacement of the entire meter pedestal unit should it become damaged or non-usable.

Meter pedestals must be located within 10 feet of the transformer, the transformer pole, or a location pre-approved by the engineering department.

The Member is responsible for installing the service conduit from the transformer pole or pad mounted transformer to the meter pedestal. Please refer to the Service Installation section for details on this installation.

Meter Poles

The Member is responsible for obtaining and assembling the materials needed for constructing a meter loop, a drawing of which is included in this guide. The

Cooperative will attach the fully assembled meter loop to the pole and will make the source connections at the top of the pole. See attached drawing "A."

The following wire sizes are required for the various service sizes:

Service Size	Length of Service (ft)	Copper Wire	Aluminum Wire
200	<=200ft		4/0 AL
200	<300ft	4/0 Cu*	
320	<=200ft	4/0 Cu*	350MCM AL
320	<300ft		500MCM AL

"*" – 4/0Cu wire may not be immediately available and subject to changing lead times and market prices if member requests it to be ordered.

A service disconnect (fused or circuit breaker) sized appropriately to the size of the meter loop wires and load to be served shall be installed for all underground circuits.

VI. Other Service-Related Items

If the location of the requested service is more than 300 feet from an existing high voltage power line, then the primary line will need to be extended. This primary line can typically be extended overhead or underground. All facilities indicated in this document as being provided by the Cooperative are assumed to be for a permanent residence. The cost for other types of service requests are evaluated on the usage and permanence of the requested services.

Overhead Primary

Un-insulated wires attached to insulators on poles, generally 25 feet in the air. The line is constructed within a 30-foot-wide easement also referred to as a Right-of-Way which will be cleared of all trees, brush, and tall vegetation, from ground to sky. This is the member's responsibility for initial service. The Cooperative will maintain the ROW after service is established.

The Cooperative will provide the transformer pole and overhead transformer for a permanent residence. Member, in cooperation with CREC, can locate the transformer pole where desired, within 150ft of the residence. Member will pay for the take-off of the primary overhead line and an anchor (if an additional pole is required for anchoring, additional charges apply) if transformer pole is located

within 250ft of primary line. If located over 250ft, Member will be responsible for each pole and span of wire required to reach said transformer pole. See below.

Additional length or spans can be provided on a unit cost basis as designed by the Service Planning Technician.

A metered secondary service is required to obtain usable voltage in the home.

Member Action Items:

- Easement
- Right-of-Way Clearing

Underground Primary

An insulated conductor is installed underground in conduit with a minimum of 48" of cover after backfilling. This type of line is constructed within a 15-foot-wide easement cleared of all large trees.

The Cooperative will provide the pad-mounted transformer located within 150' of the home.

The Member is responsible for the cost of everything other than the transformer.

The trench, conduit, wire, and other required materials can be provided on a unit cost basis by the Cooperative and as designed by the Service Planning Technician. Alternatively, the Member can provide and install the trench and conduit.

A metered secondary service is required to obtain usable voltage in the home.

Member Action Items:

- Easement
- Right-of-Way
- UG Primary Installation (See UG 60)

Easement

An easement is a legal document which provides the Cooperative with certain property rights that allow it to own, access, and maintain the primary electric facilities on your property. The easement rights are necessary to allow the Cooperative to utilize all or a portion of the electric line to provide service to future property owners adjacent to your property. The easement area is 30 feet wide for an

overhead line and 15 feet wide for an underground line for the entire length of the primary lines. The Cooperative will provide the easement document. The easement must be signed by all property owners in the presence of a notary public. The easement can be signed at a Cooperative office, bank, or any institution that has a notary public. The Cooperative will record the executed easement in the applicable county. If other persons' properties must be crossed to extend service, the Cooperative will endeavor to obtain easement from them. Ultimate responsibility for obtaining the easement will fall on the new member. No Cooperative construction will proceed until all required easements have been obtained.

Right of Way Clearing

All trees must be removed from the Right-of-Way, otherwise known as the easement area, and will be maintained in that manner. Buildings and other structures are not permitted within the Right-of-Way.

The Member is responsible for the cost of clearing the Right-of-Way for new construction. The Member may clear the ROW themselves for purposes of new line construction or pay a contractor to accomplish the work. In all cases, 30 feet of clearance, ground to sky, must be obtained. After the initial clearing, the Cooperative will maintain the Right-of-Way for the life of the line.

VII. Notice

The guidelines listed above are not a complete list of code or Cooperative requirements but a general summary of what is required. A qualified electrician will know the full requirements as to what will be needed to supply you with safe and reliable electric service. If you are not familiar with this type of construction, we highly suggest that you employ a qualified contractor to perform the work for you.

Definition of terms

Transformer: Device used to reduce the primary voltage, 14,400V or 7,200V to secondary voltage, 120 and 240 volts for use in the home or business. Normally encased within an oil filled gray tank installed on a pole or within a green cubical tank set on a concrete pad.

Pedestal: A non-metallic enclosure used to connect multiple secondary cables.

Conduit: A plastic pipe used to protect wire.

Riser: A section of conduit used to protect wire as it enters or exits the ground.

Primary (voltage): The distribution voltage used by the Cooperative to supply power to a general area. These wires and cables are energized at either 7,200 volts or 14,400 volts.

Secondary (voltage): The supply voltage used at homes or businesses. These voltages can be 120/240 volts for homes and three phase voltages such as 120/208 and 277/480 volts for businesses.

Easement: Legal permission for a third party such as a municipality or utility to locate and maintain facilities on private property.

AWG: A wire sizing convention for wires sized 4/0 (four aught) and smaller. The larger the AWG number, the smaller the size of wire.

MCM: A wire sizing convention for measuring the circumference of wire (Million Circular Mils). The larger the number the larger the size of wire.

Meter Base: A metal box that has provisions for the installation of the electric service meter.

Meter Pedestal: A manufactured device that incorporates a meter base, a riser, structural support, main breaker, and service disconnect into one assembly.

Schedule: A sizing convention for indicating the wall thickness of pipe and conduit. Typical sizes, increasing in grade, are DB, 20, 40 and 80.

Permanent Residence: A residence meeting all of the following criteria:

- The property title in the name of the person(s) receiving service.
- A permanent DNR compliant private or public water and sewer system.
- Occupied on a full-time basis more than 26 weeks per year.
- A mobile or modular home must be on permanent foundations with wheels and trailer tongue removed.

ENTRANCE FOR MOBILE HOMES

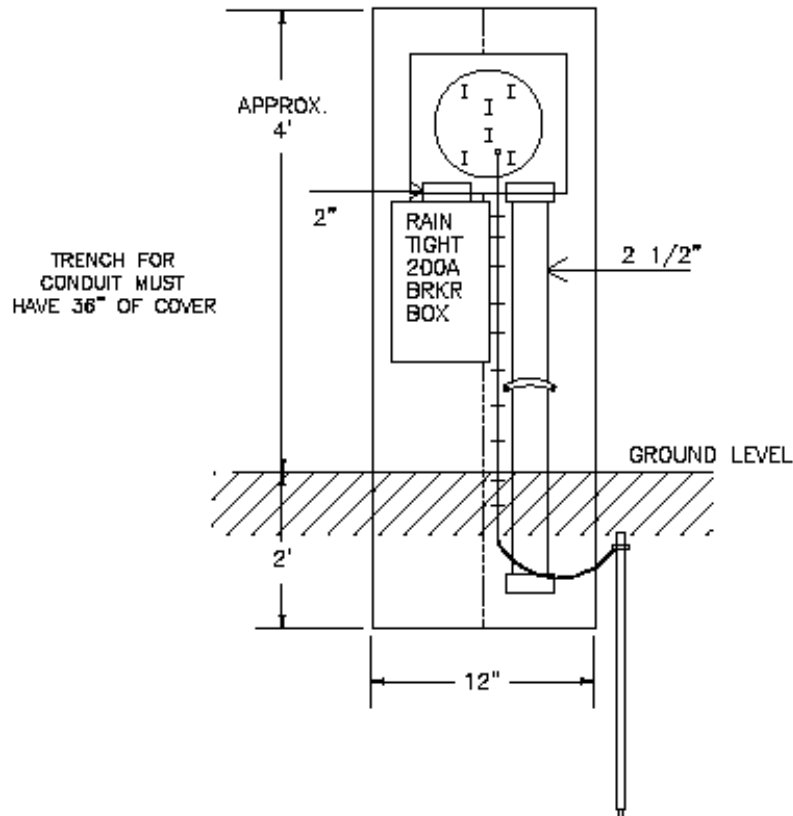

- 1 200A rain tight breaker box w/ 2" hub
- 2 2 1/2" bushing nuts
- 2 2 1/2" lock rings
- 2 2 1/2" PVC threaded adapters
- 2 2 1/2" Sch. 40 PVC pipe - 5' long
- 4 20 penny nails
- 6' #6 soft drawn bare copper wire
- 12 Galvanized fence staples
- 1 5/8" x 8' copper plated ground rod
- 1 Ground rod clamp
- 2 2 1/2" PVC couplings
- 2 6" x 6" x 6' treated timbers, min.

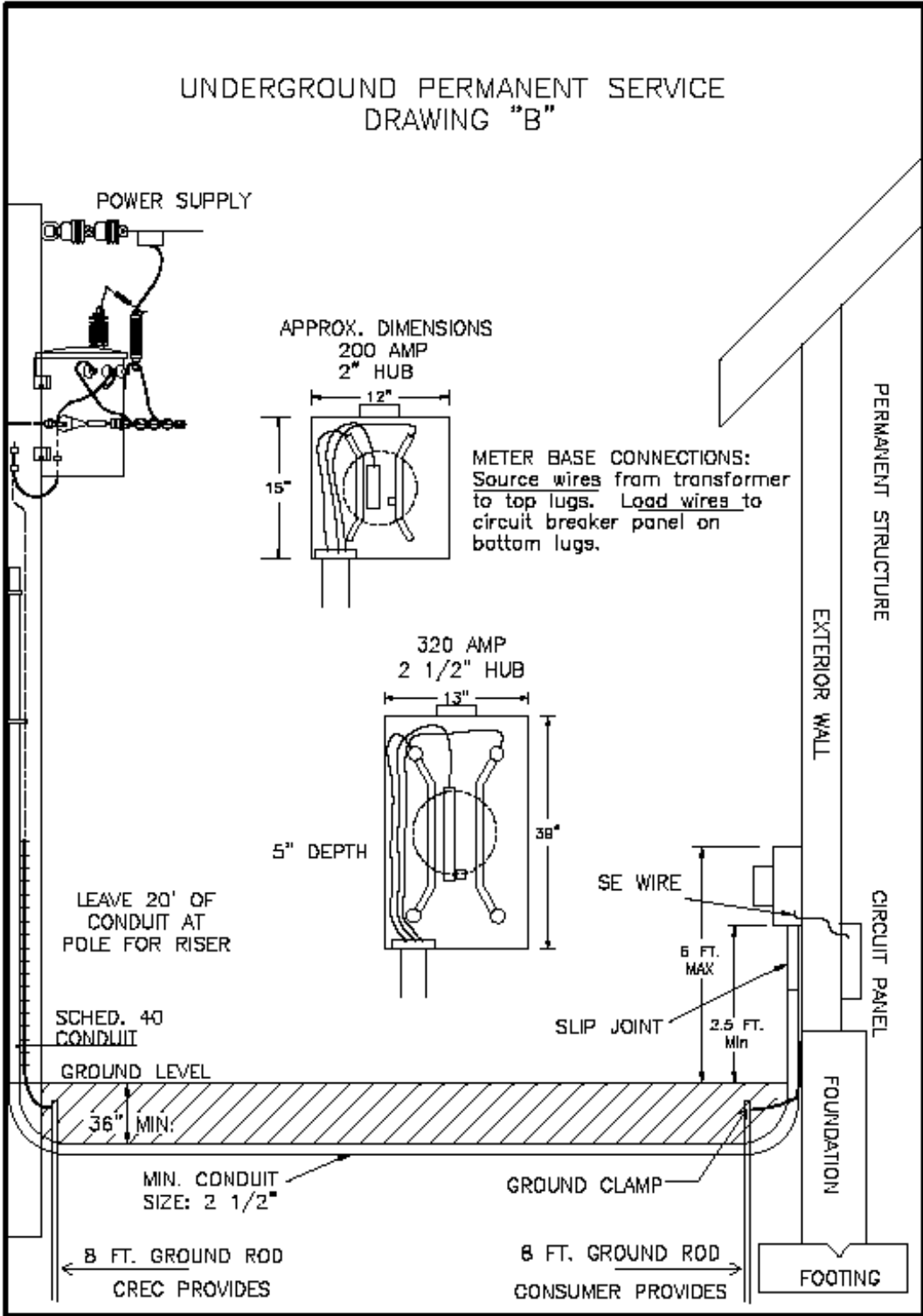

METER POLE INSTALLATION DRAWING "A1"

