



# Cuivre River Electric Cooperative

A Touchstone Energy® Cooperative



*For more information contact: Engineering Department (636) 695-4904*

Specification for:

**Individual Underground**

**Primary Line Extension**

**Form #UG60**

1. Application

This document specifies the minimum requirements a contractor must meet with the installation of single phase underground electric facilities for the purpose of Cuivre River Electric Cooperative providing electric service to an individual Member. The Contractor will be responsible for correcting or compensating the Cooperative for any installed facilities not in compliance with these specifications. All facilities supplied and installed for the intended use of Cuivre River Electric Cooperative will, upon acceptance by the Cooperative, become the property of the Cooperative as contributed by the Property Owner(s) as an aid to construction for the project.

2. General

2.1. In accordance with Cooperative Policy 602.0, the Cooperative will accommodate a Member requesting an underground primary extension to a permanently occupied residence. The Cooperative defines a "Permanently occupied residence" as a residence meeting all of the following criteria:

- The property titled in the name of the person(s) receiving service.
- A permanent DNR compliant private or public water and sewer system.
- Occupied on a full-time basis more than 26 weeks per year.
- A mobile or modular home must be on permanent foundations with wheels and trailer tongue removed.

2.2. The Cooperative will charge the Member for the labor and materials to install a riser (transition from overhead conductors to underground) on an existing pole and a pad mounted transformer. The Member will also be financially responsible for the material, labor, and all related electrical facilities between the riser pole and the last transformer necessary to provide the requested electric service. If the primary extension incorporates both overhead and underground facilities, the Member will be responsible for the clearing of Right of Way and the full cost of any additional overhead facilities. Secondary service from the transformer to the residence or metering point will be in accordance with the Cooperative Installation Guide **UG40 "Rural Residential Service Installation Guide."**

2.3. The Member requesting service may elect to employ the Cooperative or a contractor approved by the Cooperative to install electric facilities between the riser pole and the transformer(s). The Cooperative will attach the riser to the pole, connect the primary cable, install, and connect the transformer and other related facilities. The Member will be provided a firm proposal, based on Standard Unit Cost, for the Cooperative providing the installation or completing an installation performed by a contractor. **If the installation as supplied by a contractor does not meet the Cooperative specifications, the contractor will be responsible for bringing the installation within specifications prior to the Cooperative connecting the extension.**

Feb 17, 2023

Form UG60, Revision 1.4

- 2.4. The Cooperative will evaluate site conditions in the planning stages of the job. If heavy rock is evident or if the Cooperative is employed to open the trench and is unable to do so utilizing standard trenching equipment, the Cooperative will cease trenching operations and the Member will be responsible for opening the remainder of the trench. The Member may also choose to abandon the underground extension and convert to an overhead extension. In either case, the Member will be charged for the distance of trench opened by the Cooperative.
- 2.5. A Member requesting underground primary service will be responsible for executing a **Right-of-Way easement** on a form provided by the Cooperative. The Member will also be responsible for clearing a 15' wide straight path for the trenching equipment including removing any tree stumps greater than six inches in diameter that will impede the trench. After the installation is complete, the Member will be responsible for maintaining the Right-of-Way free of large species trees and heavy vegetation for the life of the service.
- 2.6. If any part of the underground extension is likely to be usable for extending service to or through adjoining properties, the Member will be responsible for establishing a means for continuing the primary extension using a second conduit or a junction enclosure. The Member must also execute an agreement to provide an easement to the Cooperative for the primary extension to the adjoining property.
- 2.7. All provided construction will meet or exceed the latest editions of all applicable building and safety codes. The editions include, but are not limited to:
  - National Electrical Safety Code (NESC)
  - Local City and County Building and Fire Codes
  - American Concrete Institute (ACI)

### 3. Installation

- 3.1. An underground line extension should be fully designed and specified by a CREC Service Planning Technician prior to excavating any trenches. The design will indicate the take-off point location, route, location of pull boxes and transformer as required, and the types of products to be utilized. **The Cooperative reserves the right to reject any installations that do not adhere to the designs and specifications of the Cooperative.**
- 3.2. Based on the qualifications of the contractor and preferences of the owner, the Cooperative will specify the conduit product to be installed between the take-off point and the transformer. This will either be PVC stick conduit or CIC which is a continuous PE conduit with the primary wire preinstalled within the conduit. **The CIC product is only available to contractors approved by the Cooperative.**

3.3. The contractor is required to open the primary and secondary trenches, install the conduit products as specified, install pull boxes as required, setup the transformer location(s), and install the meter base including the wiring between the meter base and main panel.

- **Primary trench depth of cover: 48" minimum cover over conduit**
- **Secondary trench depth of cover: 36" minimum cover over conduit**

4. Specification Summary:

4.1. Primary-side Conduit

- 2 ½" Schedule 40 gray conduit
- Elbows: 36" or 48" radius only
- Maximum of two angle deviations between riser and transformer • 200# pull string installed in conduit run
- Conduit elbow must abut riser pole.
- **Do not trench within 2 ft. of pole anchor**
- Cooperative requires an Easement required for all primary facilities
- If the trench to be occupied by the primary conduit is solid rock or contains rock of a gradation that could damage the conduit, the conduit shall be bedded/backfilled in the trench with screenings to protect the conduit from said rock

4.2 Transformer Setup

- Primary and secondary conduits to be contained within the 12" x 23" pad opening as indicated in attached drawing
- Secondary conduit(s) installed at 45 degree angle to pad orientation
- Stubbed conduits for future services shall be capped and marked.
- Excavated area under and within a 5ft area of the transformer shall be backfilled to the full depth with 1" clean rock (Quarry rock)
- Transformer must be located within 150 ft. of the residential meter location
- Transformer and transformer pad will be installed by the Cooperative who will also terminate wire in the transformer.

4.3 Secondary Service

- 2 ½" Schedule 40 gray conduit
- Elbows: 36" radius
- 36" depth of cover over conduit in the trench
- Other utilities in the trench must be horizontally separated by 1 ft.
- No gas lines allowed within the electric trench
- Maximum of three angle deviations between transformer and meter base
- Slip joint below meter base with 18"-24" travel
- 200# pull string installed in conduit run
- Compact or jet soil below meter base

Feb 17, 2023

Form UG60, Revision 1.4

- Use service entrance cable to connect the bottom lugs of the meter base to the top lugs in the distribution panel
- Install 5/8" x 8' copper clad ground rod at meter location.

ENTRANCE FOR MOBILE HOMES

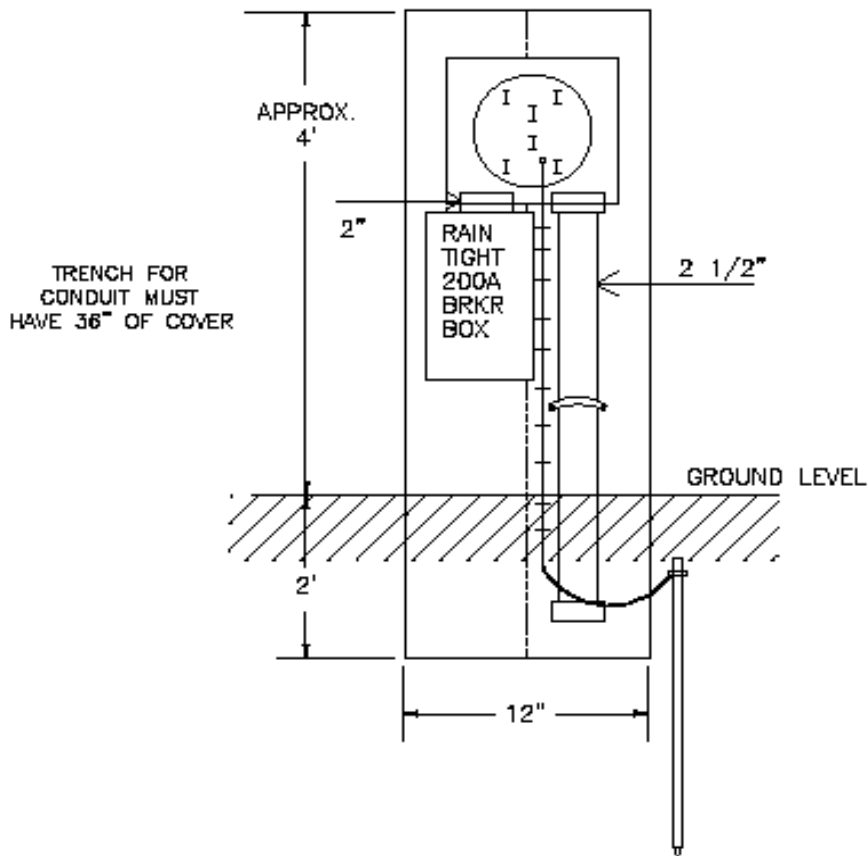

- 1 200A rain tight breaker box w/ 2" hub
- 2 2 1/2" bushing nuts
- 2 2 1/2" lock rings
- 2 2 1/2" PVC threaded adapters
- 2 2 1/2" Sch. 40 PVC pipe - 5' long
- 4 20 penny nails
- 6' #8 soft drawn bare copper wire
- 12 Galvanized fence staples
- 1 5/8" x 8' copper plated ground rod
- 1 Ground rod clamp
- 2 2 1/2" PVC couplings
- 2 6" x 6"x 6' treated timbers, min.

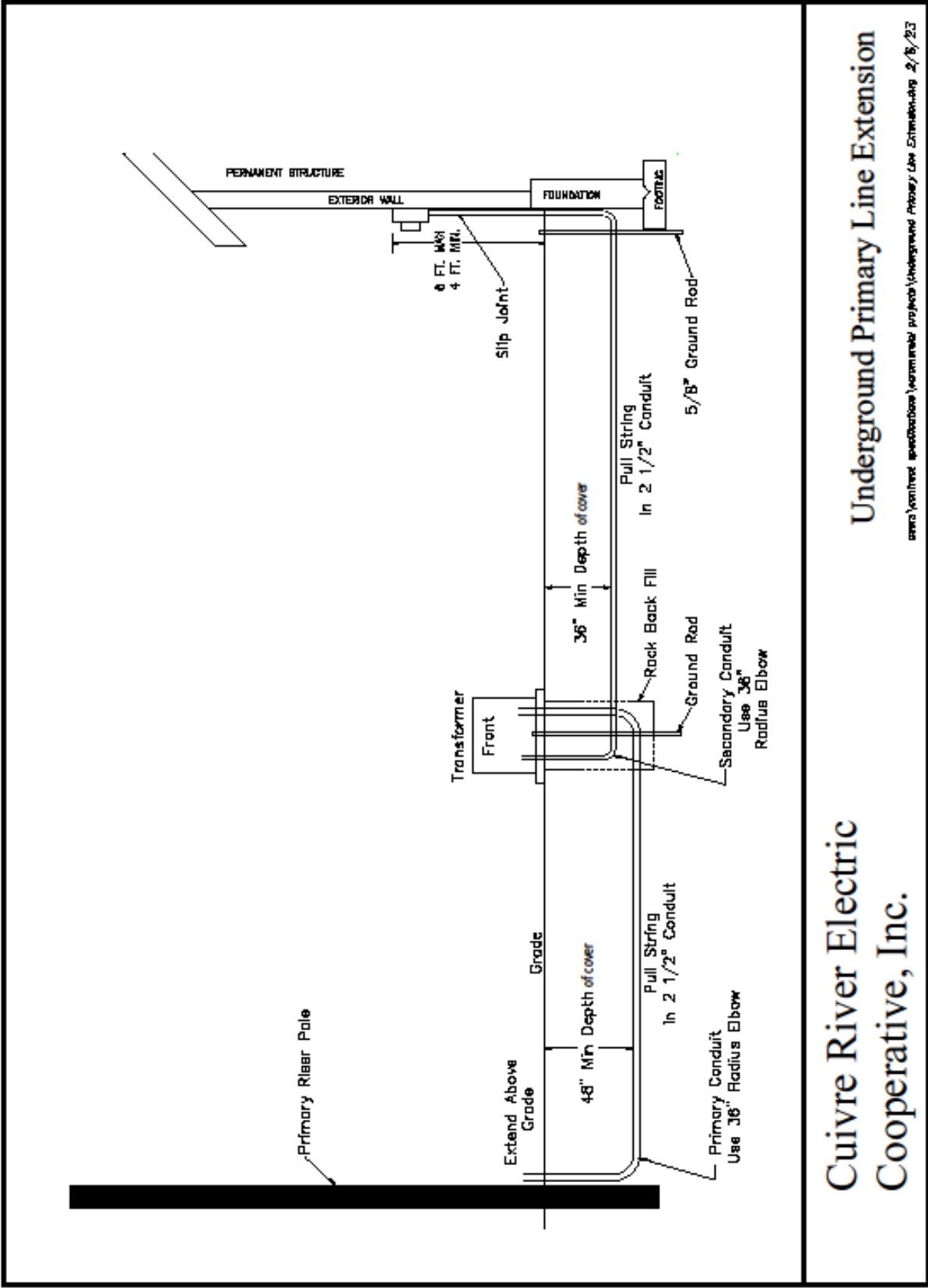

Underground Primary Line Extension  
c:\csm\third\specifications\formal\project\Underground Primary Line Extension.dwg 2/18/23

Cuivre River Electric  
Cooperative, Inc.

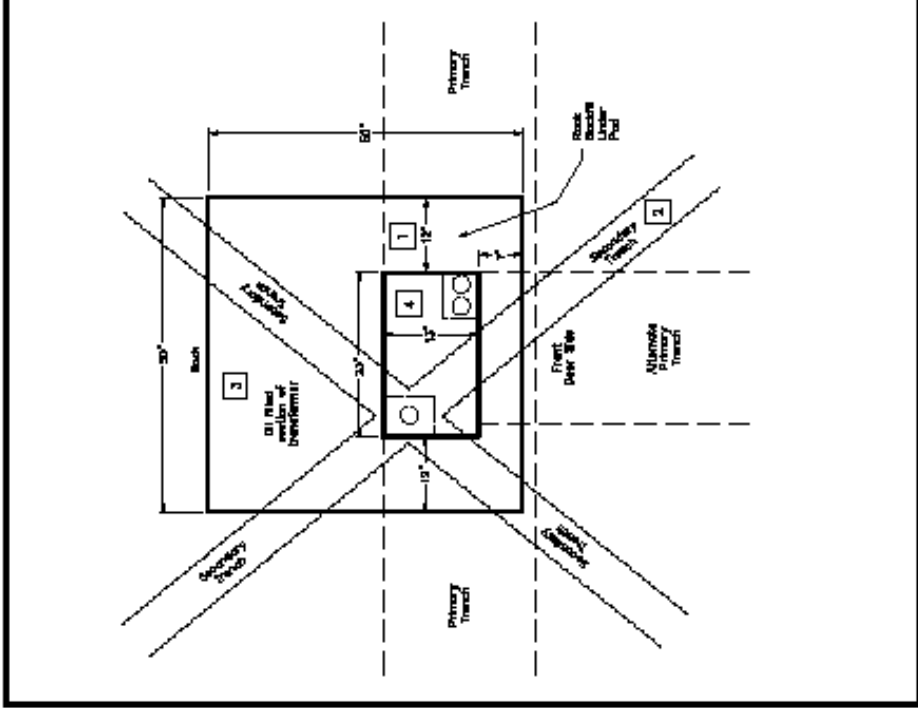
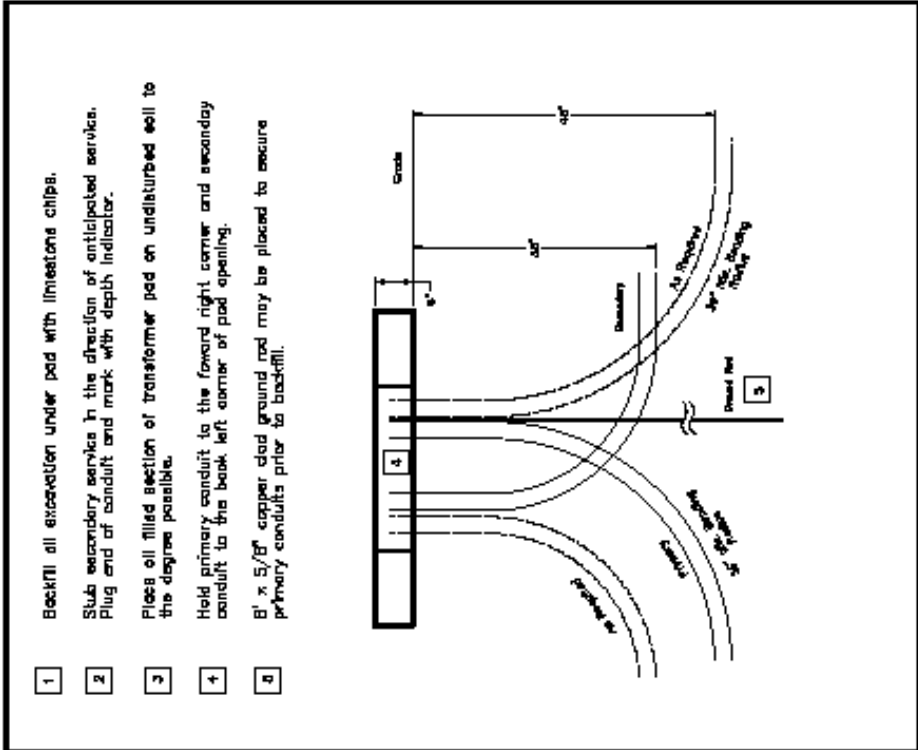

- 1
- 2
- 3
- 4
- 5

Backfill all excavation under pad with limestone chips.

Stub secondary service in the direction of anticipated service. Plug end of conduit and mark with depth indicator.

Place all filled section of transformer pad on undisturbed soil to the degree possible.

Hold primary conduit to the forward right corner and secondary conduit to the back left corner of pad opening.

6" x 5/8" capper clad ground rod may be placed to secure primary conduits prior to backfill.

**Residential Transformer Setup**

Cuivre River Electric Cooperative, Inc.

www.cuivre.org/transformer\_setup/transformer\_setup\_2/8/23